

## DM-S02

Legal Size  
**2-Drawer**  
Steel Vertical File Cabinet  
with Lock

**Dimensions:** 28 3/4"H x 17 7/8"W x 24 3/8"D

Steel construction has a baked enamel finish over rust-inhibiting.  
Label holders and a One Key core-removable lock kit.

---

**handle with care**

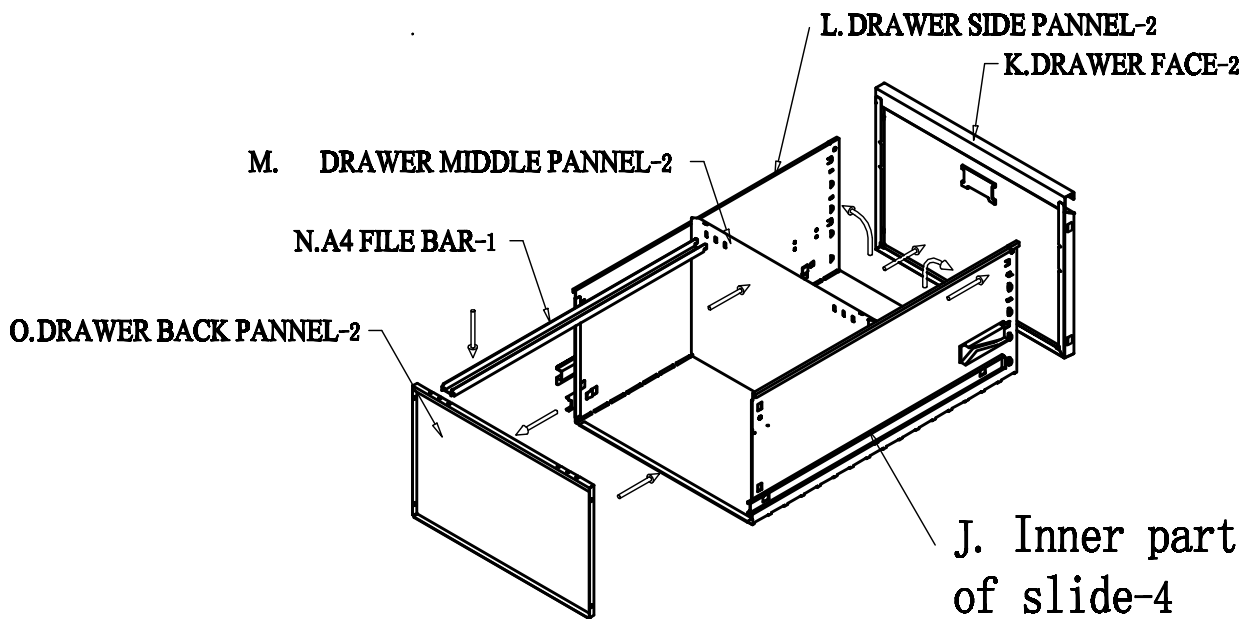
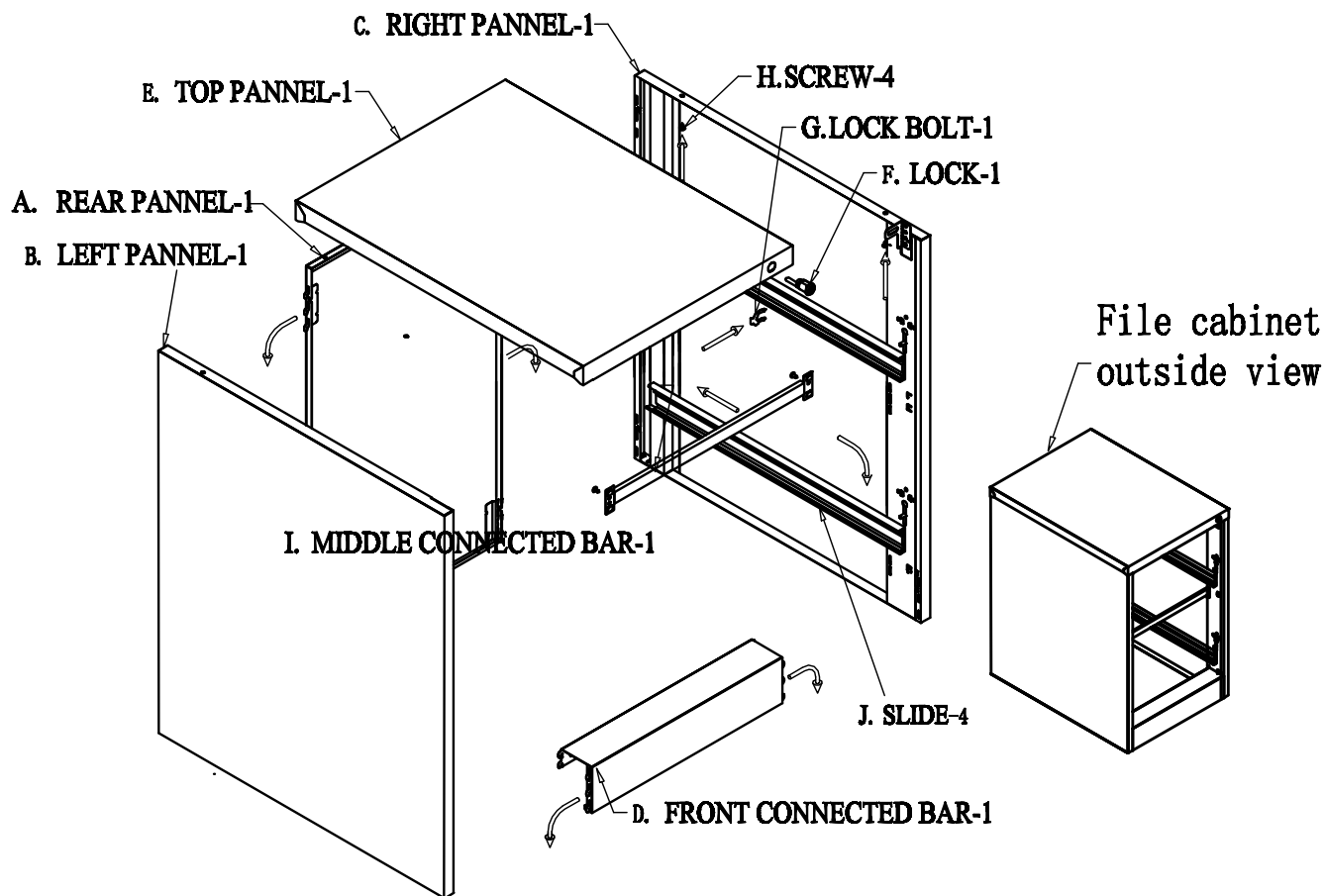

# DM-S02 (Parts List)

## 2-Drawer Steel Vertical File Cabinet

assembly instruction of filing cabinet(page A)

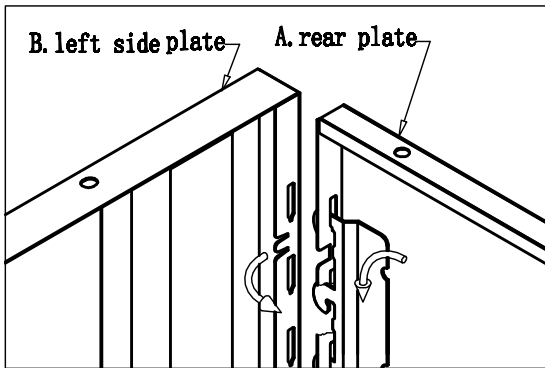

step 1:A and B.Put the hook of part A into the grooved position at back of part B,push toward down, bend the tab in the part B to clip the part A

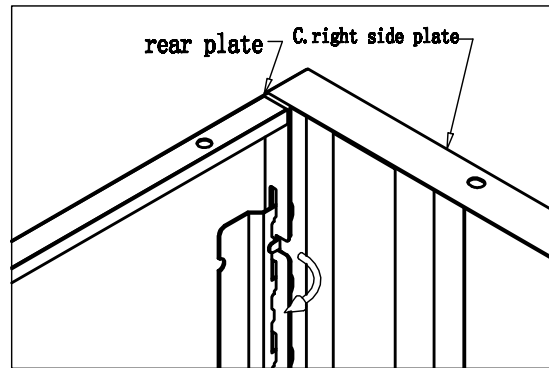

step 2A and C.Put the hook of part A in to the grooved position at back of part C,push toward down, bend the tab in the part C to clip the part A.

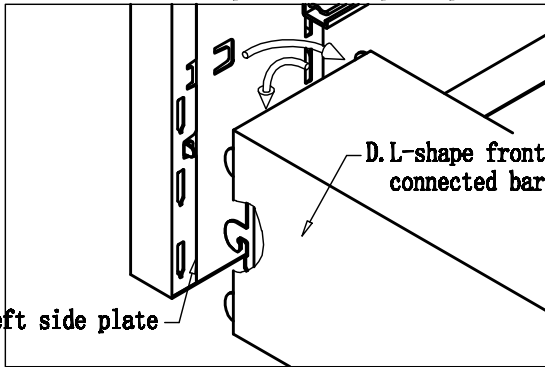

step 3D and B.Put the hook of part D into the grooved position at front of part B,push toward down,bend the tab in the part B to clip the part D

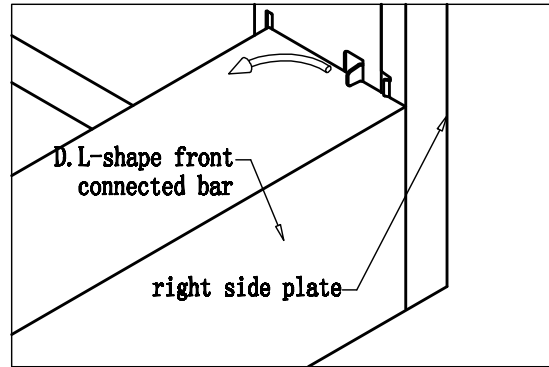

step 4D and C.Put the hook of part D in to the grooved position at front of part C,push toward down, bend the tab in the part C to clip the part D.

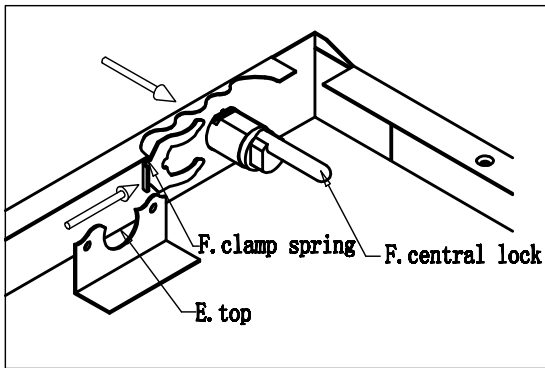

step 5E and F.push F central lock in to the hole of E, clip the F central lock with F clamp spring and put it to the limit position toward the direction as arrow shows.

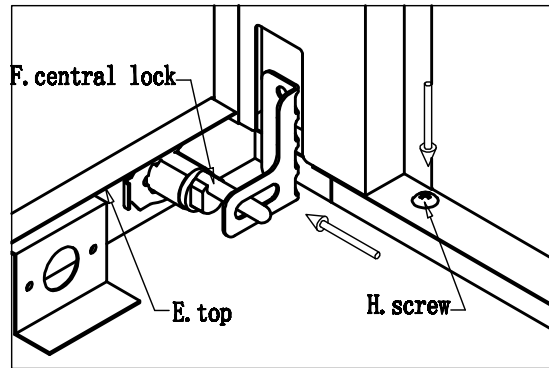

step 6E and ABCD.Cover the cabinet unit with E,insert lock bar of F to the hole of A.fix E and cabinet unit with screws

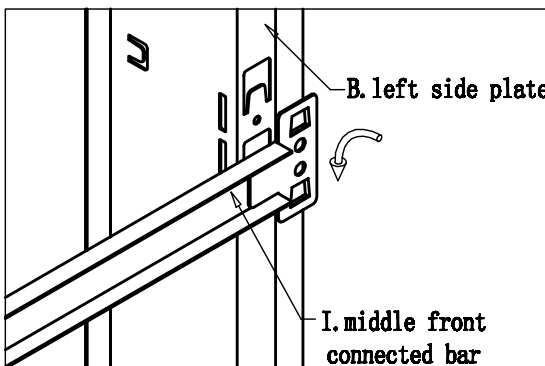

step 7I and ABCDE.put both sides of I into the clamps in A and B,push toward down.

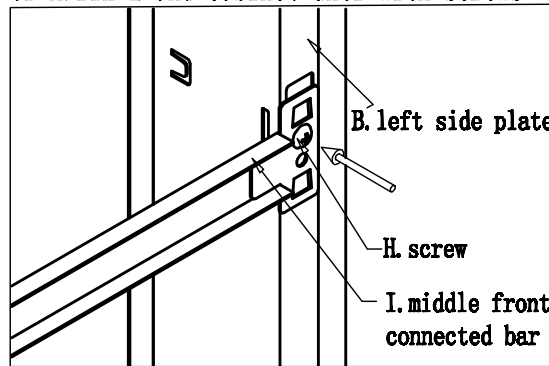

step 8I and ABCDE.fix I and ABCDE with screws.

assembly instruction of filing cabinet (page B)

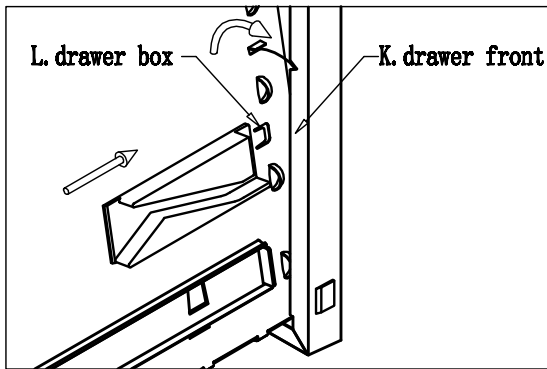

step 9:K and L. Put L into K rotatably as the arrow direction, join K and L.

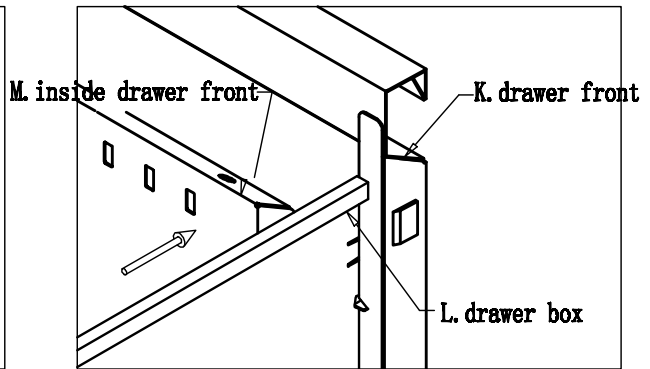

step 10M and KL. Push M into unit KL as the arrow direction, fix K and L.

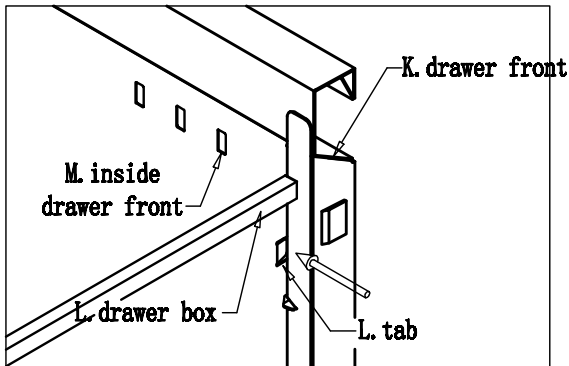

step 11M and LK. Push the tab of L inward by 2mm, fix M and LK.

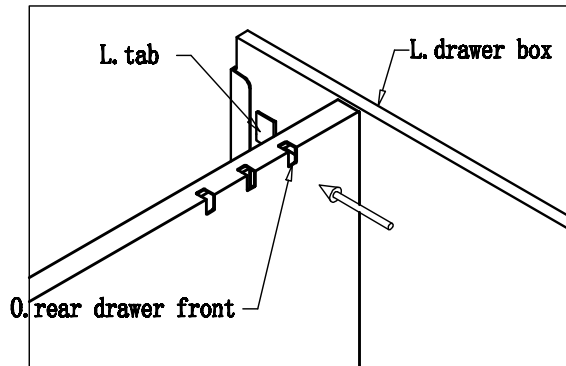

step 120 and L. Put the O into L and push backward as arrow direction to make three sides of O into the three ruffle of L.

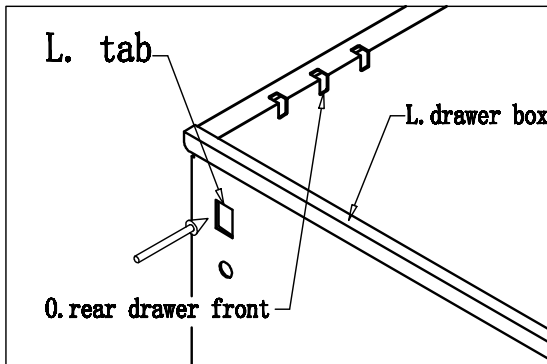

step 130 and L. Push tab of L inward by 1.5mm as arrow direction to make O fixed in the ruffles of L.

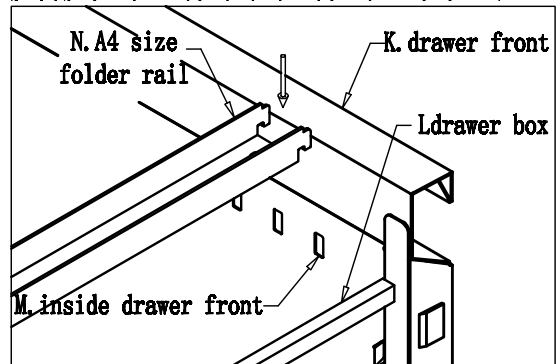

step 14N and M. Insert N into the grooved part of M as arrow direction.

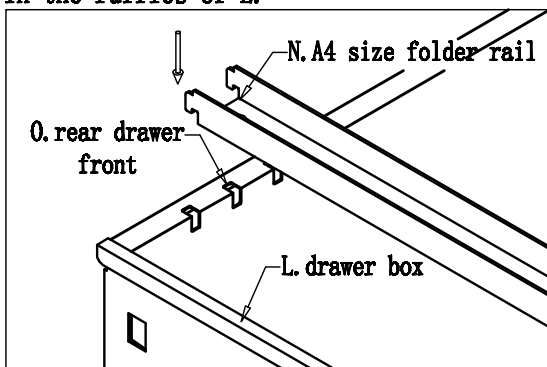

step 15N and O. Insert N into the grooved part of O as arrow direction. 1

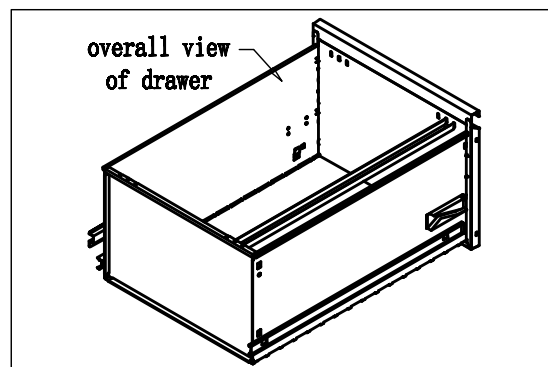

step 16repeat same steps to fix other drawers.